

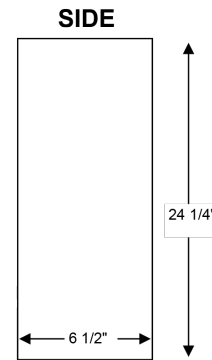

# Armour Fire Safety

## ECS-999 EXTINGUISHER CABINET

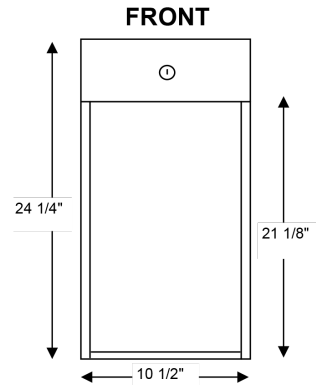

National Fire's Classic series are surface mounted cabinets that are both practical and economical. Theft and vandal resistant; these cabinets remain locked at all times, allowing emergency access through means of breaking the scored plexi glass. Cabinets come complete with scored plexi, breaker bar, key and decal. Perfect for parking garages, warehouses, industrial areas and construction sites.

<b>Fire Extinguisher Capacity (Dry Chemical)</b>	10 lb
<b>Width</b>	10-1/2 in
<b>Height</b>	24-1/4 in
<b>Depth</b>	6-1/2 in
<b>Door &amp; Tub</b>	18 GA. Galvanized Steel Construction
<b>Finish</b>	Electrostatically Applied Baked White Enamel Paint
<b>Label</b>	UV Resistant Decal
<b>Includes</b>	Keyed Alike Cylinder Lock with Key Breaker Bar & Chain Scored Acrylic (21-3/4" h X 10-3/8" w)

